

# HiFi ENGINE®

For more Hi-Fi manuals and set-up information  
please visit [www.hifiengine.com](http://www.hifiengine.com)

# QUAD

# 99

## 909 Stereo Power Amplifier



Instruction Manual

# QUAD

## 909

### **909 Stereo Power Amplifier Instruction Manual**

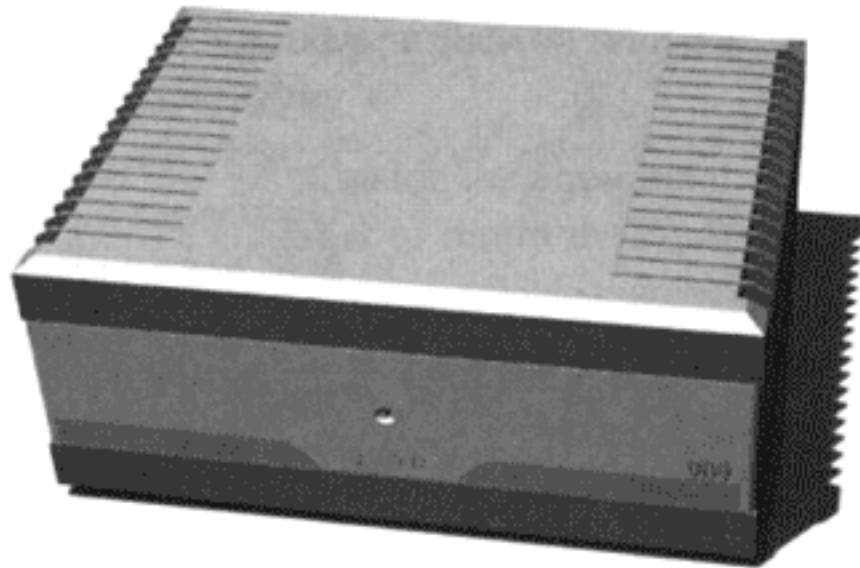

### **CONTENTS**

IMPORTANT NOTES .....	2
INTRODUCTION .....	3
PACKING LIST AND UNPACKING THE EQUIPMENT .....	4
GUARANTEE AND PRODUCT REGISTRATION .....	4
SERVICE ARRANGEMENTS .....	4
ACCESSORIES .....	5
INSTALLATION .....	5
SPECIFICATIONS .....	12

## **IMPORTANT NOTES**

### **European Union Directives**

Quad equipment is designed to comply with the legal provisions of EU Directives 89/336/EC and 72/23/EEC. The standards which have been applied were those in force at the time of the introduction of the product.

The product bears the CE mark: 

Compliance cannot guarantee perfect performance. In the very rare circumstance that you experience problems you should first try to locate and remedy the origin of any disturbance. A further option is to relocate the Quad equipment in order to reduce the interference. Your dealer should be able to provide assistance if the problem persists.

### **FCC Rule 15 Class B**

This equipment has been tested and complies with the limits for a Class B device, pursuant to Part 15 of the FCC Rules. These limits are designed to provide reasonable protection against harmful interference in a residential installation. This equipment generates, uses and can radiate radio frequency energy and, if not installed and used in accordance with the instructions, may cause harmful interference to radio communications. However, there is no guarantee that interference will not occur in a particular installation. If this equipment does cause interference to radio or television reception, which can be determined by turning the equipment off and on, the user is encouraged to try to correct the interference by one or more of the following measures:

- Re-orient or relocate the receiving antenna
- Increase the separation between the equipment and the receiver
- Connect the equipment into an outlet on a mains circuit different to that to which the receiver is attached
- Consult the dealer or an experienced radio/TV technician for help

This Class B apparatus meets all the requirements of the Canadian Interference Causing Equipment Regulations.

### **Information to the user**

Alteration or modifications carried out without appropriate authorisation may invalidate the user's right to operate the equipment.

It is always good practice to switch off equipment before connecting or disconnecting signal leads. This will prevent unpleasant and loud noises coming from the loudspeakers and avoid the risk of damage to equipment.

This equipment is double insulated and does not need a safety earth. It is important, though, that any equipment connected to it is earthed according to the manufacturers' instructions. This becomes more important as the number of units which are connected together increases.

### **Noise Pollution**

Please be aware that very high sound pressure levels can cause permanent damage to your hearing and also severe annoyance to neighbours.

## INTRODUCTION

The Quad 909 is a stereo power amplifier primarily intended for use with very high quality sound reproducing systems in the home and we hope that it will give you much pleasure. It will normally be used in conjunction with a Quad pre-amplifier though other pre-amplifiers can be used.

You should read the following useful notes before you begin to install and use the equipment. The notes are directed towards responsible adults who can ensure safe installation of the equipment. Minors should not attempt electrical installation or carry out changes.

The Quad 909 amplifier weighs approximately 12kg and is built to be robust. Remember to check that any surface on which you place it is stable and is able to support this weight.

There are no user adjustable parts inside the equipment. You should refer any servicing to a qualified engineer or return the equipment to either the dealer or the Quad distributor.

## Current Dumping

The 909 amplifier uses a current dumping output circuit, a Quad invention (covered by patents in several countries) which eliminates many of the problems associated with transistor amplifiers. In a current dumping amplifier there is in effect both a low power, very high quality amplifier and a high power, heavy duty amplifier. The low power amplifier controls the loudspeakers at all times calling on the high power amplifier to provide most of the muscle. The low power amplifier is so arranged – it carries an error signal – that provided the larger power transistors (the current dumpers) get within the target area of the required output current, it will fill in the remainder accurately and completely. The reproduced quality is solely dependent on the small amplifier which, because of its low power, can be made very good indeed.

Problems of crossover distortion, quiescent current adjustment, thermal tracking and transistor matching all disappear. There are no internal adjustments or alignments and the choice of power transistor types is less restrictive.

The performance of the Quad 909 amplifier is as accurate as it is possible to achieve by careful design, selection of components and rigorous test procedures.

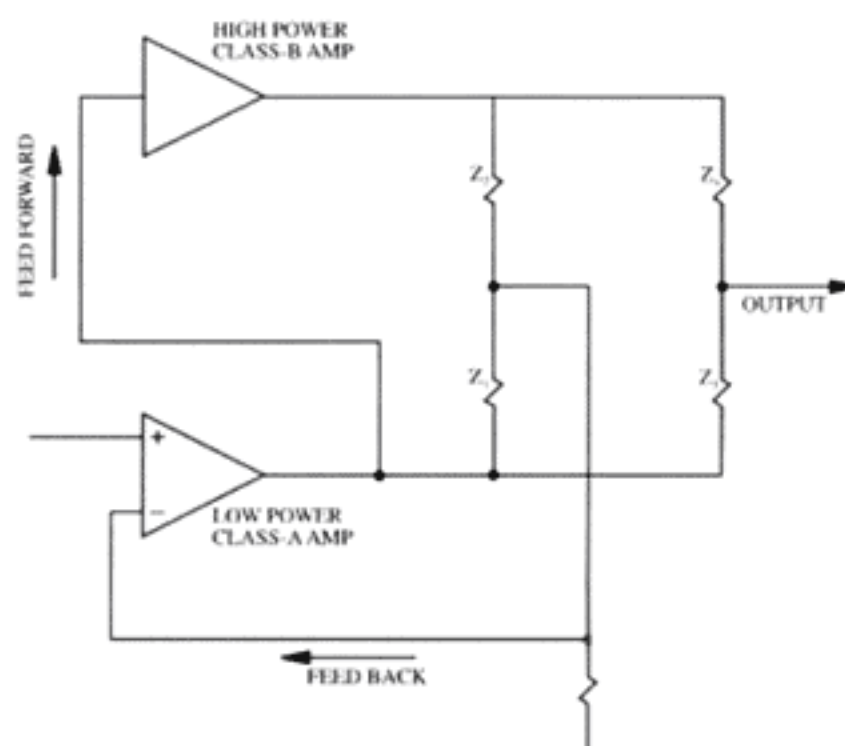

**Simplified Diagram of a current dumping amplifier**

## **PACKING LIST AND UNPACKING THE EQUIPMENT**

The packaging contains the following items:

- The 909 Stereo Power Amplifier
- One IEC mains lead fitted with an appropriate mains connector;  
for UK this is QUKES2B  
for Europe this is QE2P2S2  
for USA, Japan and Korea this is QU3ES2C  
for other territories an appropriate cable will be supplied.
- One 1m long 99 Ampbus connector and cable, Q37404A
- Instruction Manual
- Warranty Registration Form
- One set of packing materials comprising:
  - One set of expanded foam end caps
  - One cardboard carton
  - One polythene protective bag

Consult the dealer from whom you purchased the equipment if any of these items are not present.

Please retain the packing materials for future use or return them to your dealer. If you decide not to keep the packing, please dispose of it sensibly. The paper and plastics components are recoverable and may be taken to an appropriate recovery service.

Please retain the user manual and the information concerning the date and place of purchase of this equipment for future reference.

## **GUARANTEE AND PRODUCT REGISTRATION**

Your Quad equipment is guaranteed against any defect in material and workmanship for one year from the date of purchase (proof of purchase required). We ask that you complete and return the enclosed Warranty Registration Form. This will also enable us to keep you informed of future Quad products. Within the guarantee period, Quad will undertake replacement of defective parts free of charge provided that the failure was not caused by misuse, accident or negligence. Your statutory rights within the territory in which you purchased the equipment are not affected by this guarantee.

Quad carries out a regular review of its products and reserves the right to adjust the specifications and performance from time to time.

There are no user replaceable or serviceable parts inside this equipment. Unauthorised attempts to service or modify this product will invalidate the warranty.

## **SERVICE ARRANGEMENTS**

If your Quad equipment requires servicing you should return it to the dealer from whom the equipment was purchased.

If you are abroad and there is no suitable dealer in your area, please contact

the distributor for the country in which it was purchased or Quad Electroacoustics Ltd.

Equipment returned for service should use the original packing. You should enclose a brief note with your name and address and the reason for returning the equipment.

## ACCESSORIES

We have provided this equipment with a simple selection of accessories which will allow this equipment to work with other units such as a cassette tape recorder, video player or other hi-fi equipment. The following optional accessories are also available.

<b>Accessory description</b>	<b>Part No.</b>
IEC mains cable 2m, fitted with UK plug	QUKES2B
IEC mains cable 2m, fitted with European plug	QE2P2S2
QuadLink bus cable 160mm	Q37414A
QuadLink bus cable 1m	Q37404A
Double ended phono cable 500mm	QP2P2SA
Double ended phono cable 1m	QP2P21A
Double ended phono cable 2m	QP2P22A

*Note: We do not supply loudspeaker cables terminated with 4mm plugs nor the 4mm plugs themselves.*

## INSTALLATION

The Quad 909 amplifier has no controls other than an on/off switch (which is normally left on) and may be mounted out of sight in a cabinet or other convenient location. If used close to a record deck or other equipment susceptible to hum, it may be necessary to increase the spacing between them.

To keep the bus connections simple, place the 909 amplifier below the 99 pre-amplifier. Power amplifiers can be placed alongside or out of sight using a long 99 AMPBUS cable.

The amplifier will be warm when running, the actual temperature depending on the power output. A resettable current trip will automatically switch the amplifier off under gross overload or short circuit output etc. The fins of the heatsink should be kept clear of obstruction to allow adequate ventilation in normal use.

See **Amplifier Protection** on page 9.

### Checking the AC power supply

The 909 amplifier is supplied in four versions suitable for connection to either 230V, 220V, 115V or 100V AC power supplies. Before connecting the amplifier to the AC supply, check that you have the correct version – the operating voltage is clearly marked on the back. No damage will be caused if the amplifier is connected to a lower voltage than marked, but the maximum output power will be lower than specified.

The 909 amplifier can be converted from 230V to 115V and from 220V to 110V, or vice versa, by changing connections to the transformer, as well as replacing the current trip and the mains power input fuse. The rating label should also be changed.

**These changes should only be undertaken by qualified electrical technicians. Under no circumstances should customers remove the covers from the amplifier as there are dangerous high voltages present inside.**

**Before connecting to the AC power supply, check that the voltage range marked on the back corresponds with that of the supply.**

Within the EC, the nominal mains voltage which is provided to homes is 230V AC.

Please check with the dealer if you intend to use the equipment in regions which use different values of mains voltage. The dealer will be able to determine if a simple wiring change or a replacement transformer is needed.

If you are in any doubt of the correct operational voltage, ask a qualified electrician before applying power to the equipment. The Quad 909 amplifier will work correctly within the tolerances of this voltage.

The mains supply fuse of the Quad 909 amplifier is accessible on the rear panel after the IEC mains plug has been removed. In the rare event that it has broken, you should first check for any obvious cause before replacing the fuse with one of the correct rating and type. The correct fuse values are:

<b>Country or region</b>	<b>Nominal mains voltage</b>	<b>Fuse rating</b>
Europe including UK	230V AC	T6.3AL slow blow 5x20mm
Japan	100V AC	T10AL slow blow 5x20mm
Korea, for example	220V AC	T6.3AL slow blow 5x20mm
USA, for example	117V AC	T10AL slow blow 5x20mm

You should switch off the equipment and remove the connection to the mains power outlet before changing the fuse.

### **Connecting to the AC power supply**

Quad equipment supplied is provided with a mains cable fitted with an appropriate mains plug. This plug should not be cut from the cable. If, for any reason, the plug is removed, it must be safely disposed of. It must *never* be plugged into a mains outlet.

Any replacement plug should be wired to the supplied mains cable as follows:

- the **BROWN** wire must be taken to the **LIVE** terminal
- the **BLUE** wire must be taken to the **NEUTRAL** terminal

In the UK a fused 13 Amp mains plug should be fitted with a fuse link rated to 13 Amp which conforms to BS1362. In other countries a value between 10 Amps and 15 Amps should be used at either the wall socket or at the mains distribution board.

When you are trimming or cutting cables and wires you should be careful to avoid the waste parts from falling onto or into any electrical equipment. If you are in any doubt you should consult a qualified electrical engineer.



## Connection to the pre-amplifier

This diagram shows some Quad 99 system components in a typical arrangement.

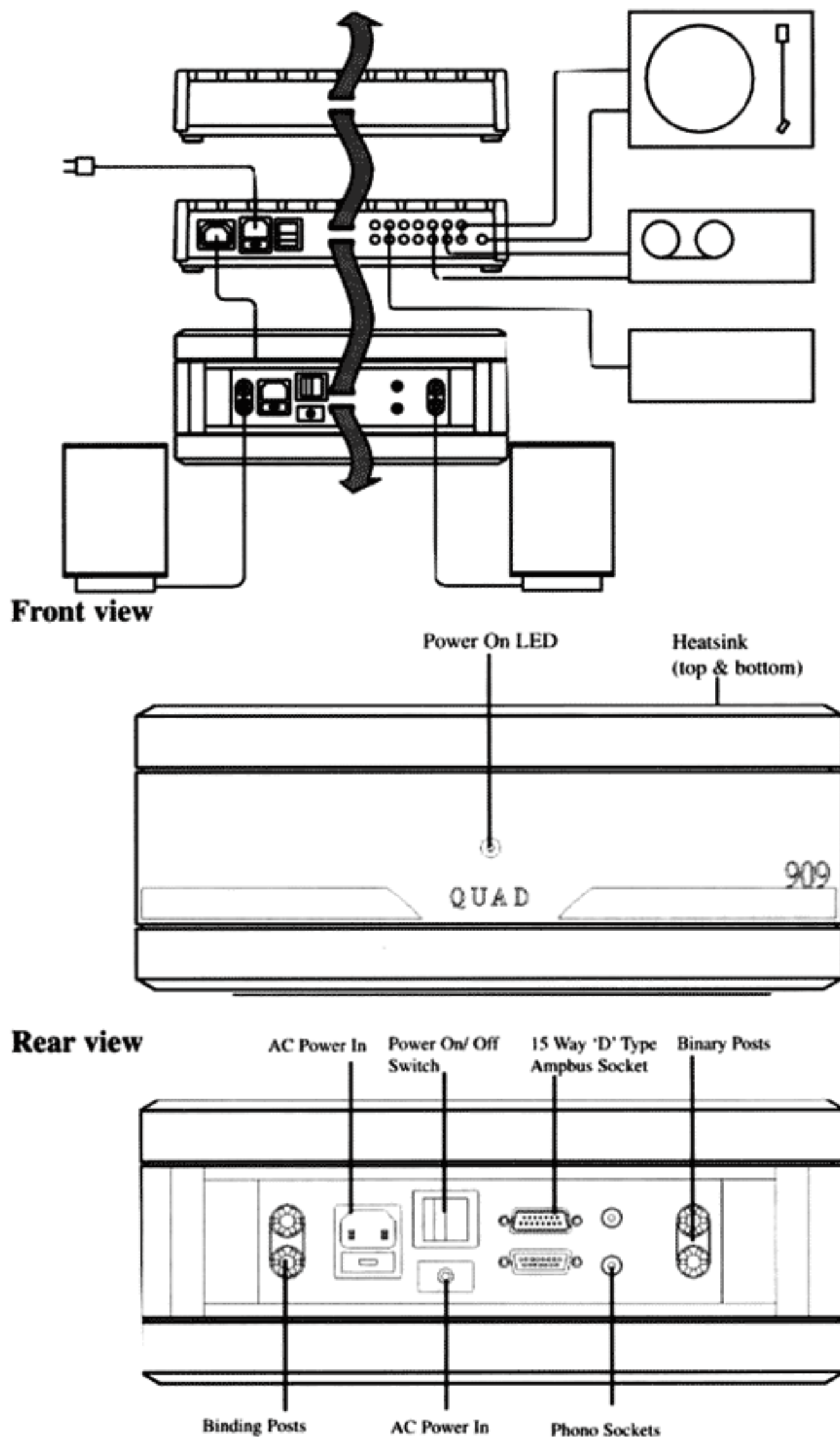

## Connecting Sockets

- Phono Sockets:** Audio input connection from the audio output of your control unit. For use only with non Quad 99 series equipment.
- Binding Posts:** Audio output to the loudspeakers
- AC Power In:** For the AC power supply input cable
- Ampbus Sockets:** Sockets for feeding and receiving information via the Quadlink

## Use of correct connectors and cables

You should ensure that any cables which are used with Quad equipment are properly terminated and that the cable is appropriate to the task. This is particularly important with loudspeaker cables and connections. If you are in any doubt you should consult your dealer.

## Connecting Loudspeakers

Loudspeaker cables should be carefully prepared. The following sketches show the preparation of a speaker cable for use with Quad power amplifiers and loudspeakers. When stripping the insulation, be careful not to cut into the wire. Make sure that you collect together all the strands of wire as stray wires may cause shorting which could result in damage or cause a fire.

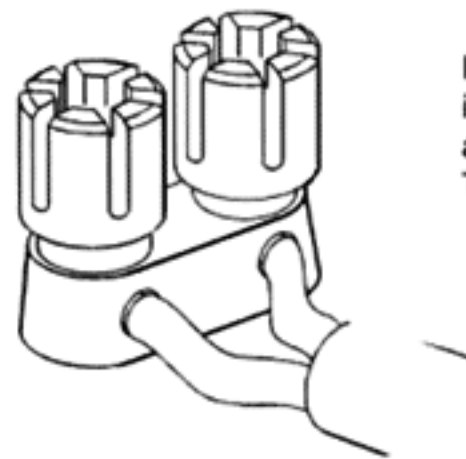
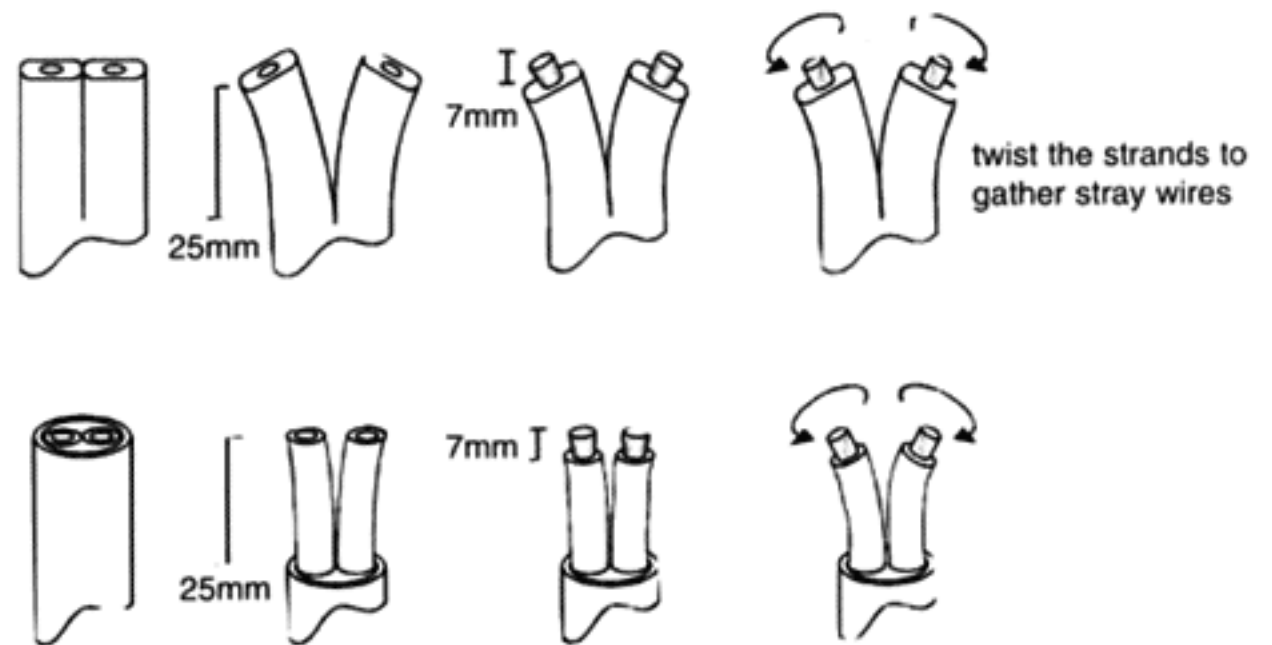

Insert the bared ends carefully into the terminal posts of the amplifier or loudspeakers. Tighten securely.

When estimating the length of loudspeaker cable, provide sufficient to enable access and tidy securing. Some cable is quite heavy and you should be careful to place your cables so that they do not cause undue strain on the binding posts of the amplifier or loudspeaker.

*Note: Please ensure that all cables used with Quad equipment are appropriate to the task and are correctly terminated. For safety reasons Quad equipment is designed not to accept 4mm connectors.*

## Phase

Make sure that both channels are connected in phase. The positive (red) output terminal of each channel should be connected to the positive (red) terminal of the speaker. Special care should be taken when bi-wiring as phase becomes critical.

## Signal Connection

When the 909 amplifier is used as part of a Quad 99 system, you should use the 99 AMPBUS lead supplied to connect to the output of the 99 pre-amplifier or 99 AV processor. Signal on the 99 AMPBUS is in differential mode, which has performance advantages over unbalanced signal.

When the 909 amplifier is used with equipment other than 99 series, you should use an appropriate lead to connect to the phono input.

## Quadlink Cable

This shows the general view of a Quadlink cable. The ends are terminated with a male and female form of the D type 15 way connector. Quad manufactures two lengths of the cable, 160mm and 1m. The 99 AMPBUS cable is actually electrically and physically identical.

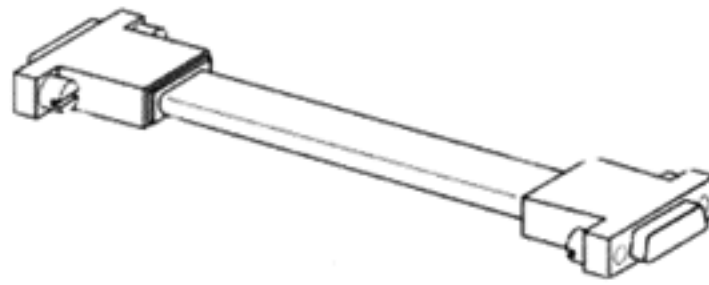

## Bi- and Tri-amplification

Two or three 909 stereo amplifiers can be used to bi- or tri-amplify loudspeakers or can be used in combination with a 99 stereo amplifier which is fitted with appropriate input connectors as an easy performance upgrade. Link the amplifiers together using Quad 99 AMPBUS connecting cable.

## Switching on and off

The on/off switch has a rocker action; press the right hand side to switch the amplifier on and the left hand side to switch it off. When the amplifier is connected to a Quad 99 system with the special AMPBUS cable this switch should normally be left switched on as the amplifier will be remotely switched. The power on LED will glow **red** when the amplifier is in standby and **green** when on.

Where the amplifier is not part of a Quad 99 system, the MAINS On/Off switch should be switched off when the amplifier is not in use.

## Amplifier Protection

The 909 amplifier is protected by a resettable current trip which interrupts the incoming AC Power supply if the amplifier is grossly overloaded for a period of time. To restore operation, simply press the red reset button on the back panel. It is thus fully protected against gross overload, short-circuited output etc, but not necessarily against seriously inadequate ventilation.

## Loudspeaker Protection

The loudspeaker manufacturer will usually state a maximum recommended amplifier power output, but as the maximum safe power for most loudspeakers is time and frequency dependent, it is difficult to define it precisely for a musical signal. Some manufacturers will permit their loudspeakers to be used with amplifiers exceeding the quoted handling, provided certain precautions are observed. This can sometimes be an advantage in enabling short duration peaks to be handled without overload. The advice of the loudspeaker manufacturer should always be obtained if in any doubt.

## **Running In your amplifier**

The performance of the amplifiers tends to stabilise after a period of use. This is due to a number of factors associated with the physical and chemical properties of the components used.

We recommend that the system be run with a music signal for several hours when it is first installed.

Although the changes can be quite subtle in nature, we find that after a few days the sound quality becomes smoother and more natural.

## **Quad Electrostatic Loudspeakers**

The 909 amplifier is fully compatible with the Quad ESL-63, ESL-988 and ESL-989 loudspeakers. It should not be used with the earlier model ESL which could be damaged by signal peaks unless a protection circuit is fitted inside each loudspeaker – please contact Quad Electroacoustics for details.

## **Loudspeaker Phasing**

If there is any doubt about the way the loudspeakers are connected, their phasing can easily be checked by playing a mono source, when the sound should appear to emanate from a point midway between the two loudspeakers. If this is indefinite, then the connections to one of the loudspeakers should be reversed. When correctly connected, the loudspeakers will give a definite centre sound source with more full bodied tenor and bass registers.

## **Headphones**

Headphones will normally be used instead of loudspeakers and there are a number of suitable switch units available designed to enable the loudspeakers to be switched off when the headphones are plugged in. Most of these incorporate a simple attenuator circuit to permit operation at normal settings of the control unit volume control. Electrostatic or other types of headphones requiring a high level input should be operated in accordance with the manufacturer's instructions.

## **Maintenance**

The surface of the equipment may be cleaned with a damp cloth provided that the power has been removed first. Solvent based cleaning materials should not be used as they may damage the paint finish.

## SPECIFICATIONS

(Measurements made with 230V supply, one channel driven and apply to either channel)

<b>Power Output</b>	140W into 8 Ohms (0.05% THD) 250W into 4 Ohms (0.05% THD)
<b>Total Harmonic Distortion</b> (100 watts into 8Ohms, 20Hz to 20kHz)	<0.01%
<b>Output impedance</b>	1.5 $\mu$ H parallel with 0.05 $\Omega$
<b>DC Offset voltage</b>	less than 10mV
<b>Frequency response</b>	-1.0 dB at 13 Hz and 40 kHz, ref 1 kHz
<b>Power response</b>	-0.25 dB at 20 Hz and 20 kHz, ref 1 kHz
<b>Input sensitivity</b>	775mV (phono input)
<b>Input impedance</b>	20 k $\Omega$
<b>Crosstalk</b>	-90 dB at 1 kHz (input loaded by 600 $\Omega$ )
<b>Signal to Noise Ratio</b> (ref. 140 watts)	108dB (20 kHz measurement bandwidth)
<b>Stability</b>	Unconditionally stable with any load and input
<b>Dimensions</b>	Width 321mm; height 140mm; depth 240mm (plus connectors) approx.
<b>Weight</b>	12kg approx.

*The right is reserved to alter performance and specification as required. This equipment complies with the radio interference requirements as laid down in EEC (European Economic Community) regulations.*

# QUAD

**Quad Electroacoustics Limited**

IAG House

Sovereign Court

Ermine Business Park

Huntingdon

Cambs PE18 6WA

## **Sales**

Telephone: 01480 433777 / 447700

Fax: 01480 431767

## **Service**

Telephone: 01480 452561

Fax: 01480 413403

## **e-mail:**

[info@quad-hifi.co.uk](mailto:info@quad-hifi.co.uk)

Quad is a member of the International Audio Group.

Quad is a Registered Trade Mark.